

PARTS LIST						
ITEM	QTY	PART NO.	PART DESCRIPTION	LENGTH	UNIT WT.	NET WT.
1	1	PL-KI	BACKING PLATE WELDMENT		12.35	12.35
2	1	PL625-72512	STANDOFF CLAMP BRACKET		16.30	16.30
3	4	AL-433	ANGLE BRACKET	3 in	2.18	8.71
4	2	L252525-8	ANGLE BRACE (FIELD MODIFICATION REQUIRED)	96 in	34.52	69.04
5	4	BP6875-10	BENT PLATE BRACKET	10 in	3.82	15.30
6	8	G58R-10	5/8" x 10" THREADED ROD (HDG.)		0.87	6.97
7	2	A582114	5/8" x 2-1/4" HDG A325 HEX BOLT	2 1/4 in	0.31	0.62
8	6	A5802	5/8" x 2" HDG A325 HEX BOLT		0.27	1.63
9	8	G58FW	5/8" HDG USS FLATWASHER	1/8 in	0.07	0.56
10	24	G58LW	5/8" HDG LOCKWASHER		0.03	0.63
11	24	G58NUT	5/8" HDG HEAVY 2H HEX NUT		0.13	3.12
TOTAL WT. #					134.59	

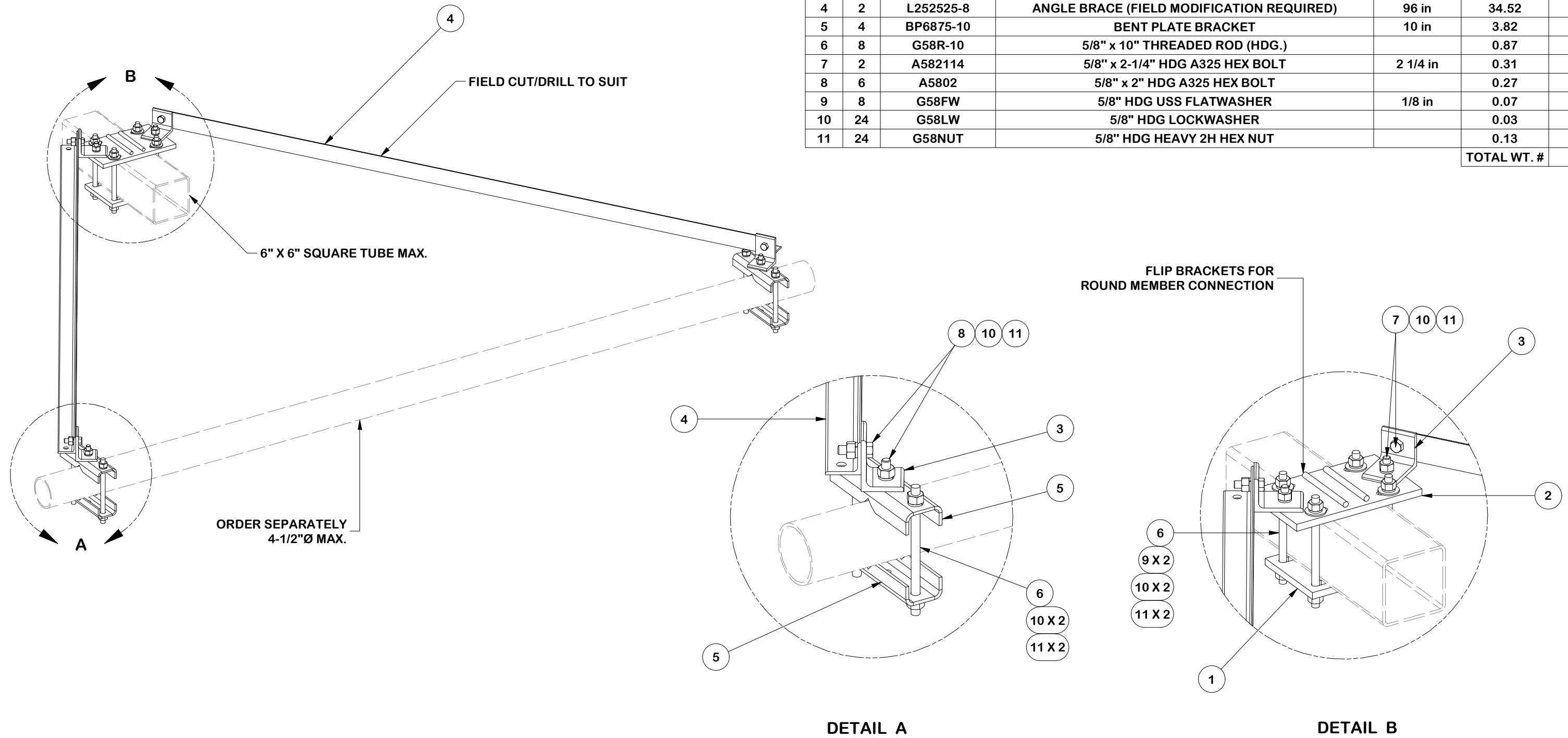

FINISH:
HOT DIP GALVANIZED.

TOLERANCE NOTES

TOLERANCES ON DIMENSIONS, UNLESS OTHERWISE NOTED ARE:
 SAWED, SHEARED AND GAS CUT EDGES (± 0.030 ")
 DRILLED AND GAS CUT HOLES (± 0.030 ") - NO CONING OF HOLES
 LASER CUT EDGES AND HOLES (± 0.010 ") - NO CONING OF HOLES
 BENDS AND ANGLES ARE $\pm 1/2$ DEGREE
 ALL OTHER MACHINING (± 0.030 ")
 ALL OTHER ASSEMBLY (± 0.060 ")

PROPRIETARY NOTE:
 THE DATA AND TECHNIQUES CONTAINED IN THIS DRAWING ARE PROPRIETARY INFORMATION OF VALMONT INDUSTRIES AND CONSIDERED A TRADE SECRET. ANY USE OR DISCLOSURE WITHOUT THE CONSENT OF VALMONT INDUSTRIES IS STRICTLY PROHIBITED.

DESCRIPTION
**UNIVERSAL HORIZONTAL SUPPORT RAIL
 BRACE KIT**

CPD NO.	DRAWN BY CMFL	ENG. APPROVAL
CLASS 87	SUB 02	CHECKED BY
DRAWING USAGE CUSTOMER		

SITE PRO 1
 Engineering Support Team:
 1-888-753-7446
 A valmont COMPANY

Locations:
 New York, NY
 Atlanta, GA
 Los Angeles, CA
 Plymouth, IN
 Salem, OR
 Dallas, TX
 Tampa, FL

PART NO. HSRB-U	PAGE 1 OF 1
DWG. NO. HSRB-U	